



SFP28 CWDM 10KM Transceiver

APS8CxxB53xDL10



SFP28 CWDM 10KM Transceiver

APS8CxxB53xDL10

ATOP's APS8CxxB53xDL10 single-mode transceiver is SFP28 module for duplex optical data communications support up to 25.78Gb/s . It is with the SFP+ 20-pinconnector to allow hot plug capability . Digital diagnostic functions are available via an I²C . It has built-in clock and data recovery (CDR). This module is designed for single-mode fiber and operates at a nominal wavelength of CWDM (1271~1371nm).

Product Features

- ✓ Duplex LC connector
- ✓ Hot-pluggable SFP28 footprint
- ✓ Operating data rate up to 25.78Gbps
- ✓ 1271~1371nm DFB laser
- ✓ RoHS compliant and Lead Free
- ✓ Distance up to 10km on 9/125um SMF
- ✓ Metal enclosure for lower EMI
- ✓ Power dissipation <1.2W(0~+70°C), <1.8W(-40~+85°C)
- ✓ Commercial and industrial operating temperature optional

Applications

- ✓ 10&25GBASE Ethernet
- ✓ eCPRI & CPRI



Product Selection

Part Number	Operating Case temperature	DDMI
APS8CxxB53CDL10	Commercial (0~70°C)	Yes
APS8CxxB53IDL10	Industrial(-40~85°C)	Yes

Note: High temp of the temp-item indicate module's case temperature.

Product Channel Selection

Part Number	Center Wavelength	Data Rate	Distance
APS8C27B53xDL10	1271nm	25.78G	10KM
APS8C29B53xDL10	1291nm	25.78G	10KM
APS8C31B53xDL10	1311nm	25.78G	10KM

APS8C33B53xDL10	1331nm	25.78G	10KM
APS8C35B53xDL10	1351nm	25.78G	10KM
APS8C37B53xDL10	1371nm	25.78G	10KM

Regulatory Compliance

- ESD to the Electrical PINs: compatible with MIL-STD-883 Method 3015
- ESD to the Duplex LC Receptacle: compatible with EN 61000-4-2
- Immunity compatible with EN 61000-4-3
- EMI compatible with FCC Part 15 Class B
- Laser Eye Safety compatible with FDA 21CFR 1040.10 and 1040.11 IEC 60950, IEC60825-1,2
- RoHS compliant with RoHS 2.0(2015/863/EU)-amending

Pin Descriptions

Pin	Symbol	Name	Ref.
1	VeeT	Transmitter Ground (Common with Receiver Ground)	1
2	TX Fault	Transmitter Fault. LVTTTL-O	2
3	TX Disable	Transmitter Disable. Laser output disabled on high or open. LVTTTL-I	3
4	SDA	2-Wire Serial Interface Data Line (Same as MOD-DEF2 in INF-8074i). LVTTTL-I/O	2
5	SCL	2-Wire Serial Interface Data Line (Same as MOD-DEF2 in INF-8074i). LVTTTL-I	2
6	Mod_ABS	Module Absent, Connect to VeeT or VeeR in Module.	2
7	RS0	Rate Select 0, optionally controls SFP+ module receiver . LVTTTL-I	4
8	LOS	Loss of Signal indication. Logic 0 indicates normal operation. LVTTTL-O	5
9	RS1	Rate Select 1, optionally controls SFP+ module transmitter. LVTTTL-I	4
10	VeeR	Receiver Ground (Common with Transmitter Ground)	1
11	VeeR	Receiver Ground (Common with Transmitter Ground)	1
12	RD-	Receiver Inverted DATA out. AC Coupled. CML-O	
13	RD+	Receiver Non-inverted DATA out. AC Coupled. CML-O	
14	VeeR	Receiver Ground (Common with Transmitter Ground)	1
15	VccR	Receiver Power Supply	6
16	VccT	Transmitter Power Supply	6
17	VeeT	Transmitter Ground (Common with Receiver Ground)	1
18	TD+	Transmitter Non-Inverted DATA in. AC Coupled. CML- I	
19	TD-	Transmitter Inverted DATA in. AC Coupled. CML- I	
20	VeeT	Transmitter Ground (Common with Receiver Ground)	1

Note

1. Circuit ground is internally isolated from chassis ground.
2. TX Fault is an open collector/drain output .Which should be pulled up with a 4.7K – 10K Ohms resistor on the host board if intended for use. Pull up voltage should be between 2.0V to Vcc+0.3V.A high output indicates a transmitter fault caused by either the tx bias current or the tx output power exceeding the preset alarm thresholds. A low output indicates normal operation .In the low state, the output is pulled to <math><0.8V</math>.
3. Laser output disabled on TX Disable >2.0V or open, enabled on TX Disable<math><0.8V</math>.
4. Internally pulled down per SFF-8431 Rev4.1.
5. LOS is open collector output. Should be pulled up with 4.7k – 10kohms on host board to a voltage between 2.0V and 3.6V. Logic 0 indicates normal operation; logic 1 indicates loss of signal.
6. Internally connected.

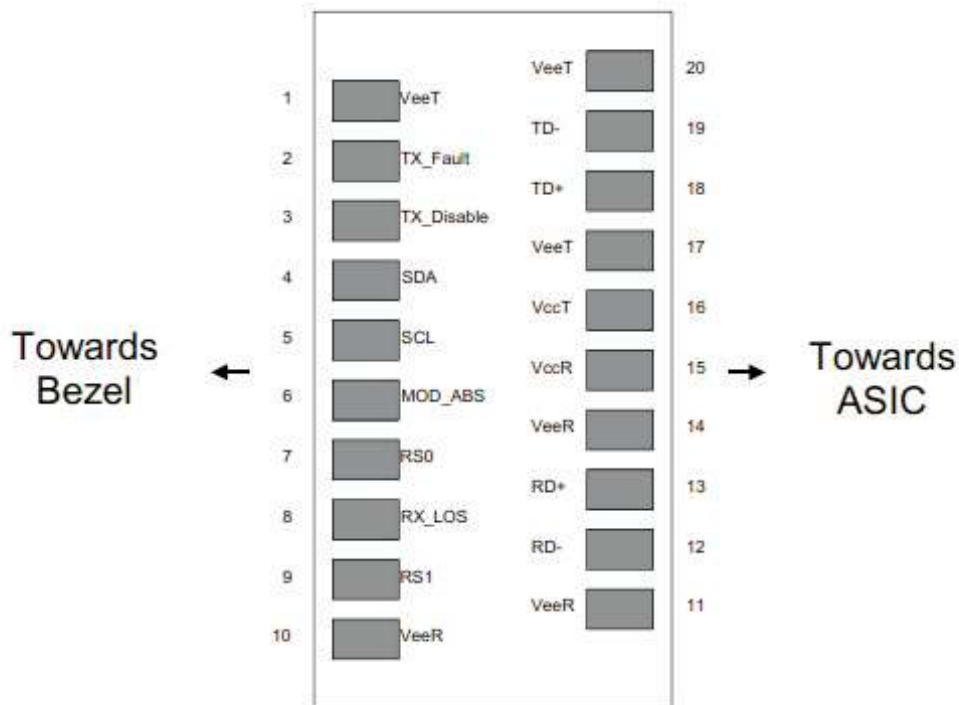

Pin-out of Connector Block on Host Board

Recommend Circuit Schematic

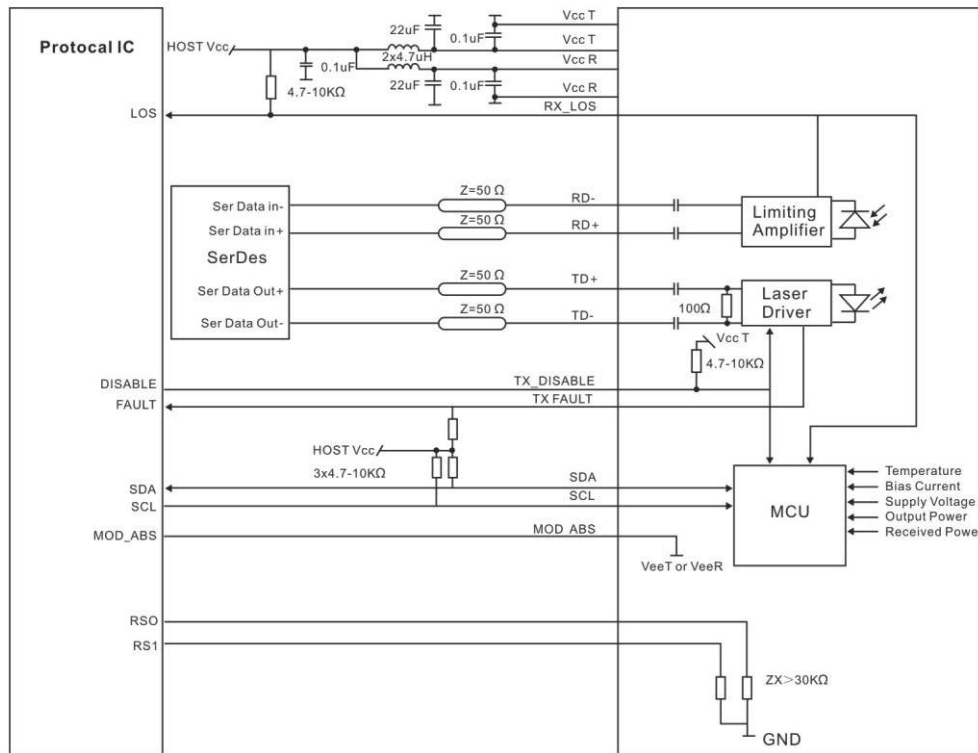

Absolute Maximum Ratings

Parameter	Symbol	Min	Typ	Max	Unit	Ref.
Maximum Supply Voltage	Vcc	-0.5		+4.0	V	
Storage Temperature	TS	-40		+85	°C	
Operating Humidity	RH	0		85	%	

Recommended Operating Conditions

Parameter	Symbol	Min	Typ	Max	Unit	Ref.
Power Supply Voltage	Vcc	3.13	3.30	3.47	V	
Power Supply Current	Icc			340	mA	Commercial
	Icc			510	mA	Industrial
Case Operating Temperature	Tc	0		+70	°C	Commercial
	Ti	-40		+85	°C	Industrial
Data Rate	BR		25.78		Gbps	
9/125um G.652 SMF	Lmax			10	km	

Electrical Characteristics

Parameter	Symbol	Min	Typ	Max	Unit	Ref.
Transmitter						
Input differential impedance	Rin	90	100	110	Ω	1
Differential data input swing	Vin, pp	120		850	mV	
TX Disable-High		Vcc - 1.3		Vcc+ 0.3	V	
TX Disable-Low		Vee		Vee+ 0.8	V	
TX Fault-High		Vcc-1.3		Vcc+ 0.3	V	
TX Fault-Low		Vee		Vee+0.8	V	
Receiver						
Differential data output swing	Vout, pp	300		850	mV	2
LOS-High		Vcc-0.9		Vcc+ 0.3	V	
LOS-Low		Vee		Vee+0.4	V	

Notes:

1. AC coupled.
2. Into 100 ohm differential termination.

Optical Characteristics

Parameter	Symbol	Min	Typ	Max	Unit	Ref.
Transmitter						
Output Opt. Power	PO	0		+6	dBm	
Optical Wavelength	λ	$\lambda-6.5$		$\lambda+6.5$	nm	
Side-Mode Suppression Ratio	SMSR	30			dB	
Spectral Width(-20dB)	σ			1	nm	
Optical Extinction Ratio	ER	3.5			dB	
Transmitter Dispersion Penalty	TDP			4.5	dB	1
Relative Intensity Noise	RIN			-128	dB/Hz	
Eye diagram{X1, X2, X3, Y1, Y2, Y3}		0.31, 0.4, 0.45, 0.34, 0.38, 0.4				2
Receiver						
RX Sensitivity @25.78Gb/s	SEN			-13.3	dBm	3
RX Sensitivity OMA@25.78Gb/s	SEN			-13.1	dBm	4
Receiver Overload		2			dBm	
Optical Center Wavelength	λ_C	1260		1610	nm	
LOS De-Assert	LOSD			-15	dBm	

LOS Assert	LOSA	-30		dBm
LOS Hysteresis		0.5	6	dB

Notes:

- 10km fiberlink over G.652 SMF, PRBS 2³¹-1 test pattern, BER =5E-5, The TDP value <2.7dB at 1271~1331nm, and TDP value <4.5dB at 1351~1371nm.
- Transmitter eye mask definition:

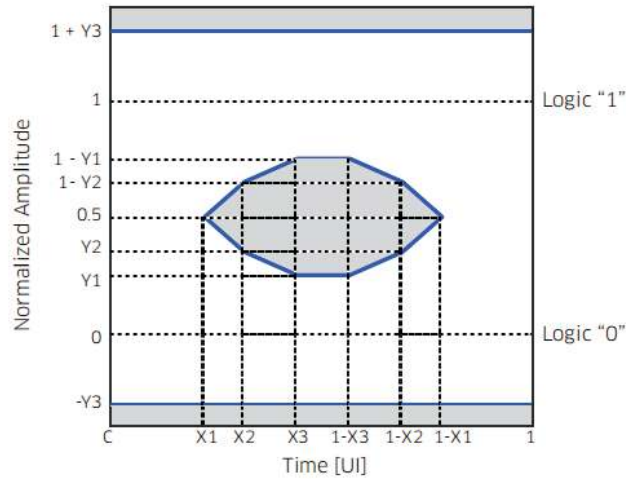

Mask of optical output eye diagram

X1	X2	X3	Y1	Y2	Y3	Max hit ratio
0.31	0.4	0.45	0.34	0.38	0.4	5 x 10 ⁻⁵

- Measured with data rate at 25.78Gb/s, BER less than 5E-5 with PRBS 2³¹-1. This value is informative and not the principal indicator of signal strength. A received power below this value cannot be compliant; however, a value above this does not ensure compliance.
- Measured with data rate at 25.78Gb/s, BER less than 5E-5 with PRBS 2³¹-1.

Mechanical Specifications

- ATOP's Small Form Factor Pluggable (SFP28) transceivers are compatible with the dimensions defined by the SFP Multi-Sourcing Agreement (MSA), dimensions are in mm.

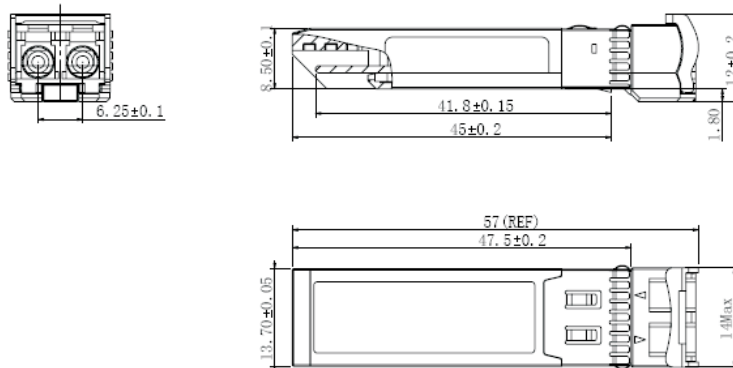

APS8CxxB53xDL10

EEPROM Information

- EEPROM memory map specific data field description is as below:

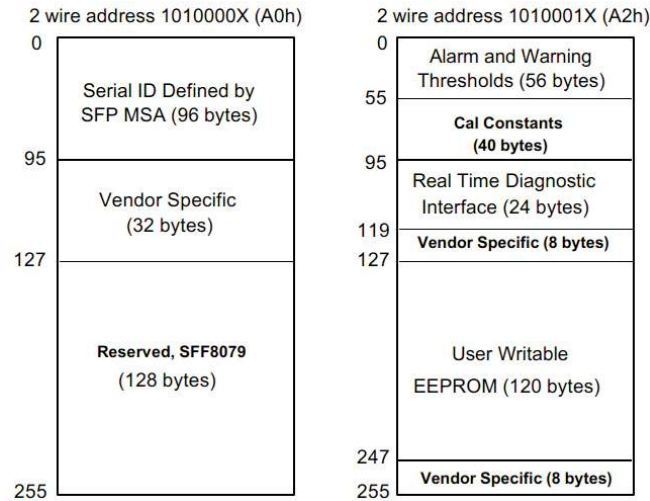

Digital Diagnostic Monitoring Interface

Five transceiver parameter values are monitored. The following table defines the monitored parameter's accuracy.

Parameter	Range	Accuracy	Calibration
Temperature	0 to +70°C (C)	±3°C	Internal
Voltage	3.13 to 3.47V	±3%	Internal
Bias Current	5 to 80mA	±10%	Internal
TX Power	0 to +6dBm	±3dB	Internal
RX Power	-14 to +2dBm	±3dB	Internal

Revision History

Revision	Initiated	Reviewed	Approved	DCN	Release Date
Version1.0	Colin Huang	Tang Zhiqiang	Ding Zheng	New Released.	Jan 15, 2019
Version2.0	Colin Huang	Tang Zhiqiang	Ding Zheng	Update TX Power.	Feb 20, 2019
Version2.1	Colin Huang	Tang Zhiqiang	Ding Zheng	Update the TDP Value by test	May 30, 2019
Version2.2	Colin Huang	Tang Zhiqiang	Ding Zheng	Update the PN by new rules	Jun 25, 2019
Version2.3	Tang Zhiqiang	Xiong Weilin	Ding Zheng	Update the TDP Value and Sensitivity Update the new template	June 13, 2020
Version2.4	Tang Rong	Tang Zhiqiang	Yuan Wei	Update Output Opt.power and add Transmitter eye mask definition	Sept 14, 2020



let's make it personal

www.atoptechnology.com