



10.3Gb/s XFP Transceiver

APX31B30xDL40



10.3Gb/s XFP Transceiver

APX31B30xDL40

ATOP's APX31B30xDL40 Small Form Factor 10Gb/s XFP transceivers are compatible with XFP MSA Specification .It is designed for use in 10G-Gigabit links up to 40km of G.652. Digital diagnostics functions are available via a 2-wire serial interface,as specified in the XFP MSA.

Product Features

- ✓ Duplex LC connector
- ✓ Hot-pluggable XFP footprint
- ✓ 1310nm DFB laser
- ✓ RoHS compliant and Lead Free
- ✓ Up to 40km for single mode fiber
- ✓ Metal enclosure for lower EMI
- ✓ +3.3V power supply and power dissipation <1.5W
- ✓ XFP MSA INF-80771 Compliant
- ✓ Compliant with IEEE 802.3ae

Applications

- ✓ 10G BASE- ER
- ✓ 10G Fibre Channel



Product Selection

Part Number	Operating Case temperature	DDMI
APX31B30CDL40	Commercial(0~70°C)	Yes
APX31B30IDL40	Industrial(-40~85°C)	Yes

Regulatory Compliance

- ESD to the Electrical PINs: compatible with MIL-STD-883 Method 3015
- ESD to the Duplex LC Receptacle: compatible with EN 61000-4-2
- Immunity compatible with EN 61000-4-3
- EMI compatible with FCC Part 15 Class B
- Laser Eye Safety compatible with FDA 21CFR 1040.10 and 1040.11 IEC 60950, IEC 60825-1,2
- RoHS compliant with RoHS 2.0(2015/863/EU)-Amending

Pin Descriptions

Pin	Symbol	Name	Ref.
1	GND	Module Ground	
2	VEE5	Optional-5.2 Power Supply-not required	
3	MOD_DESEL	Module De-select; When held low allows the module to respond to 2-wire serial interface. LVTTTL-I	
4	/INTERRUPT	Interrupt; Indicates presence of an important condition which can be read via the 2-wire serial interface. LVTTTL-O	2
5	TX_DIS	Transmitter Disable. Logic1 indicates laser output disabled, LVTTTL-I	
6	VCC5	+5V Power Supply	
7	GND	Module Ground	1
8	VCC3	+3.3V Power Supply	
9	VCC3	+3.3V Power Supply	
10	SCL	2-Wire Serial Interface Clock. LVTTTL-I	2
11	SDA	2-Wire Serial Interface Data Line. LVTTTL-I/O	2
12	MOD_Abs	Indicates Module is not present. Grounded in the Module. LVTTTL-O	2
13	MOD_NR	Module Not Ready; Indicating Module Operational Fault. Open-collector. LVTTTL-O	2
14	RX_LOS	Loss of Signal indication. Logic 1 indicates loss of Signal. Open-collector. LVTTTL-O	2
15	GND	Module Ground	1
16	GND	Module Ground	1
17	RD-	Receiver Inverted Data Output. CML-O	
18	RD+	Receiver Non-Inverted Data Output. CML-O	
19	GND	Module Ground	1
20	VCC2	+1.8V Power Supply (Not required).	3
21	P_DOWN/RST	Power down; When high, requires the module to limit power consumption to 1.5W or below. 2-Wire serial interface must be functional in the low power mode. LVTTTL-I Reset; The falling edge initiates a complete reset of the module including the 2-wire serial interface, equivalent to a power cycle. LVTTTL-I	

22	VCC2	+1.8V Power Supply (Not required)	3
23	GND	Module Ground	1
24	REFCLK+	Reference Clock (Not required)	
25	REFCLK-	Reference Clock (Not required)	
26	GND	Module Ground	1
27	GND	Module Ground	1
28	TD-	Transmitter Inverted Data Input. CML-I	
29	TD+	Transmitter Non-Inverted Data Input. CML-I	
30	GND	Module Ground	1

Note

1. Module ground pins GND are isolated from the module case and chassis ground within the module.
2. Open collector, Should be pulled up with 4.7K-10Kohms to a voltage between 3.15V and 3.6V on the host board.
3. The pins are open within module.

Pin-out Connector Block on Host Board

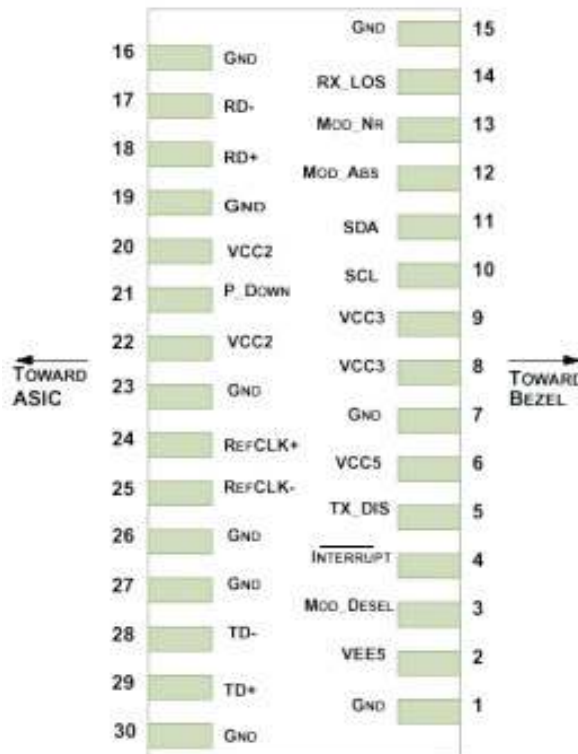

Pin-out of Connector Block on Host Board

Recommend Circuit Schematic

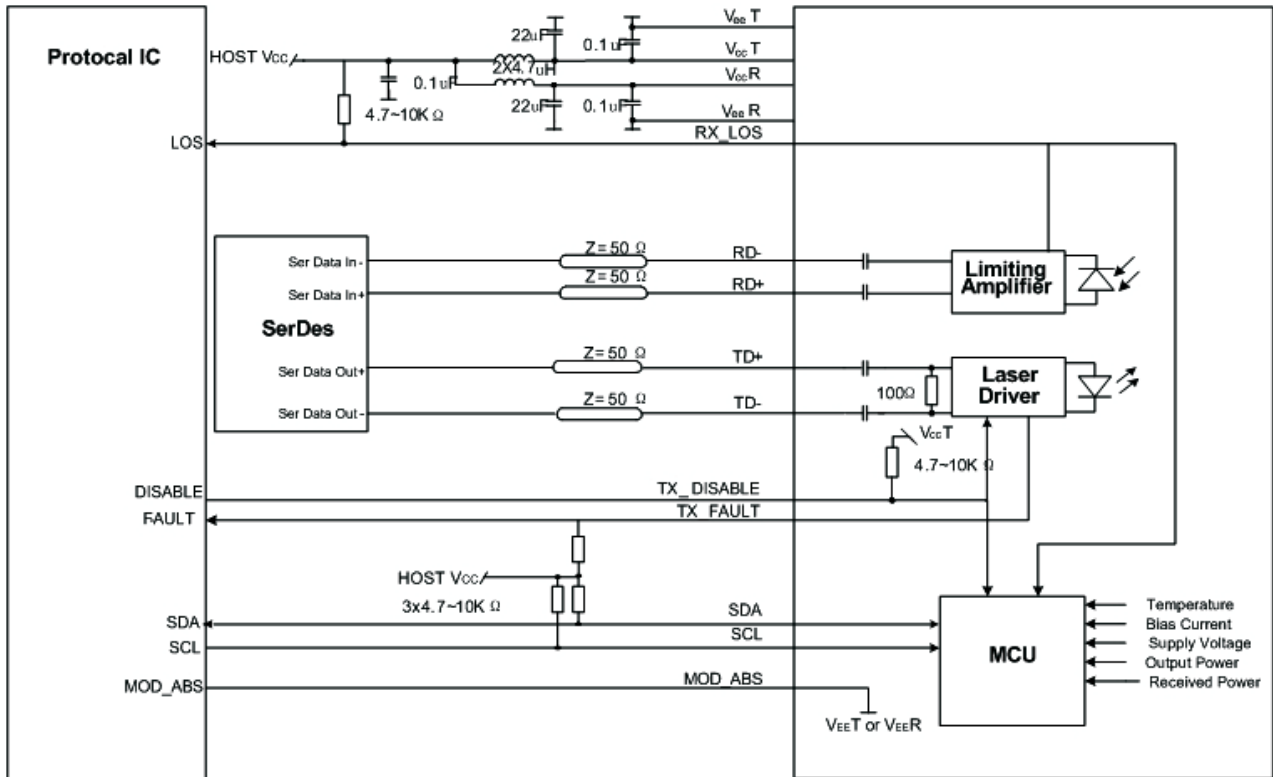

Absolute Maximum Ratings

Parameter	Symbol	Min	Typ	Max	Unit	Ref.
Maximum Supply Voltage	Vcc3	-0.5		+4.0	V	
Storage Temperature	TS	-40		+85	°C	
Operating Humidity	RH	0		85	%	

Recommended Operating Conditions

Parameter	Symbol	Min	Typ	Max	Unit	Ref.
Power Supply Voltage	Vcc3	3.13	3.30	3.47	V	
Power Supply Current	Icc3			450	mA	
Case Operating Temperature	Tc	0		+70	°C	Commercial
	Tl	-40		+85	°C	Industrial
Bit Rate	BR		10.3		Gbps	
9/125um G.652 SMF	Lmax			40	km	

Electrical Characteristics

Parameter	Symbol	Min	Typ	Max	Unit	Ref.
Transmitter						
Input differential impedance	Rin	80	100	120	Ω	1
Differential data input swing	Vin, pp	120		850	mV	
TX Disable-High		Vcc - 0.8		Vcc	V	
TX Disable-Low		Vee		Vee+ 0.8	V	
TX Fault-High		Vcc-0.8		Vcc	V	
TX Fault-Low		Vee		Vee+0.8	V	
Receiver						
Differential data output swing	Vout, pp	300		850	mV	2
Data output rise time	Tr	30			ps	3
Data output fall time	Tf	30			ps	3
LOS-High		Vcc - 0.8		Vcc	V	
LOS-Low		Vee		Vee+0.8	V	

Notes:

1. AC coupled.
2. Into 100 ohm differential termination.
3. 20 - 80 %

Optical Characteristics

Parameter	Symbol	Min	Typ	Max	Unit	Ref.
Transmitter						
Output Opt. Power	PO	+1		+6	dBm	
Optical Wavelength	λ	1260		1355	nm	
Side-Mode Suppression Ratio	SMSR	30			dB	
Spectral Width(-20dB)	$\Delta\lambda$			1	nm	
Optical Extinction Ratio	ER	3.5			dB	
Average Launch power of OFF TX	Poff			-40	dBm	
Receiver						
RX Sensitivity @10.3Gb/s	SENS			-14.4	dBm	1,2
Receiver Overload		0.5			dBm	
Optical Center Wavelength	λ_C	1260		1610	nm	
LOS De-Assert	LOSD			-15	dBm	
LOS Assert	LOSA	-30			dBm	
LOS Hysteresis		0.5			dB	

Notes:

- 1.Measured with conformance signals defined in FC-PI-2 Rev. 10.0 specifications.
- 2.Measured with PRBS 2³¹-1 at 10⁻¹² BER.

Mechanical Specifications

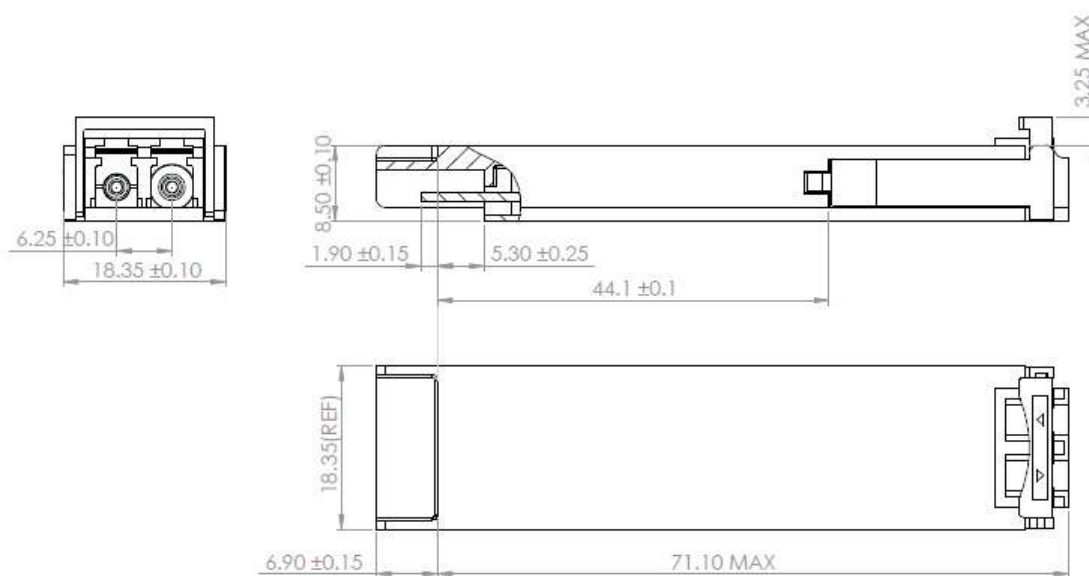

APX31B30xDL40(dimensions are in mm)

EEPROM Information

- EEPROM memory map specific data field description is as below:

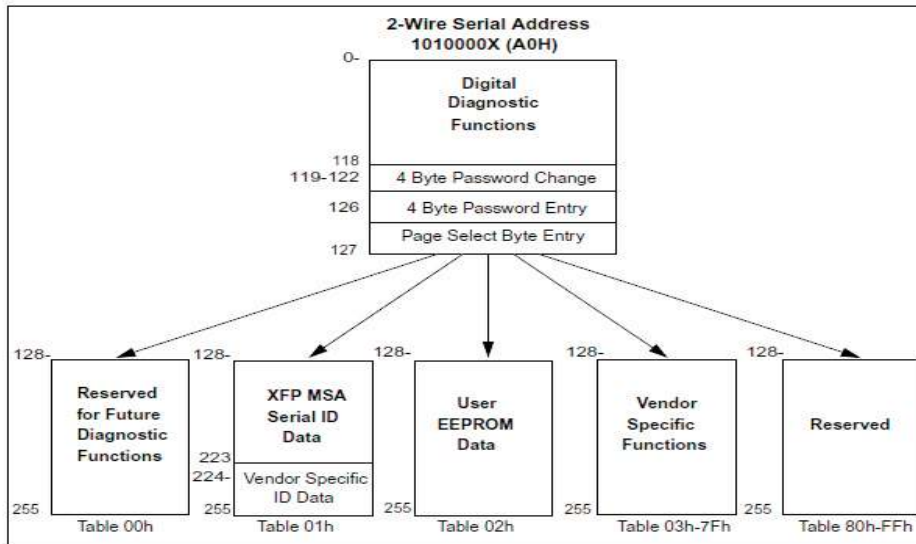

Digital Diagnostic Monitoring Interface

Five transceiver parameter values are monitored. The following table defines the monitored parameter's accuracy.

Parameter	Range	Accuracy	Calibration
Temperature	0 to +70°C (C)	±3°C	Internal
	-40 to +85°C (I)		
Voltage	2.97 to 3.63V	±3%	Internal
Bias Current	0 to 100mA	±10%	Internal
TX Power	+1 to +6dBm	±3dB	Internal
RX Power	-14.4 to 0.5dBm	±3dB	Internal

Revision History

Revision	Initiated	Reviewed	Approved	DCN	Release Date
Version1.0	yangpeiyun	Sunbin	Dingzheng	New Released.	July 28, 2016
Version1.1	Tangzhiqiang	Yangpeiyun	Dingzheng	Update the new template.	Dec 19, 2019



let's make it personal

atoptechnology.com